



Gourmet 511 Vision

Electrical Supply

CODE: 925904630

Technical features

Seats:	20/80
Outside dimension:	715 L x 800 P x 670 H mm
Space between trays:	65 mm
Trays:	5T GN 1/1
Power:	5,5 KW
Weight:	50 Kg
Max temperature:	270 ° C
Power supply:	400 V ~ 3PH + N + PE 400 V ~ 2PH + N + PE 230 V ~ 3PH + PE 230 V ~ 1PH + N + PE 50-60 Hz

Equipment

Capacitive Touch screen 7"	6 Cooking modes	5 Fan speeds
LED lighting	Core probe	HACCP register
Pre-heating option	Controlled steam injection (%)	Inner and online collection of recipes
Cooling system	Fan inversion system	Multi-timer tray cooking end
10 Phases for cooking	Multipoint probe	Glass opening for cleaning
Delayed cooking programming	Error reporting	USB port
??		

Accessories

Cabinets, Blast chillers, Exhaust & draining, Cleaning & purification, Control tools, Stands & supports, Trays

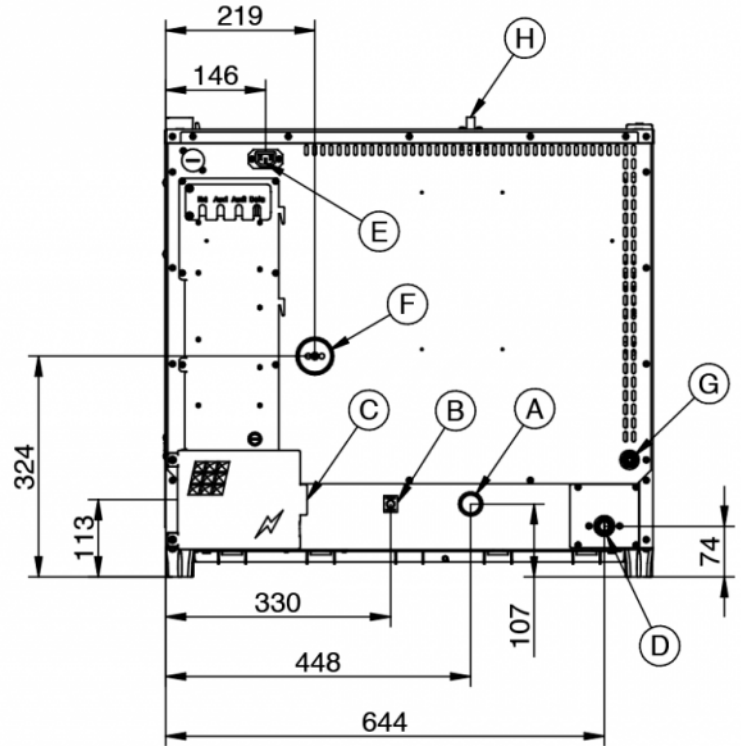
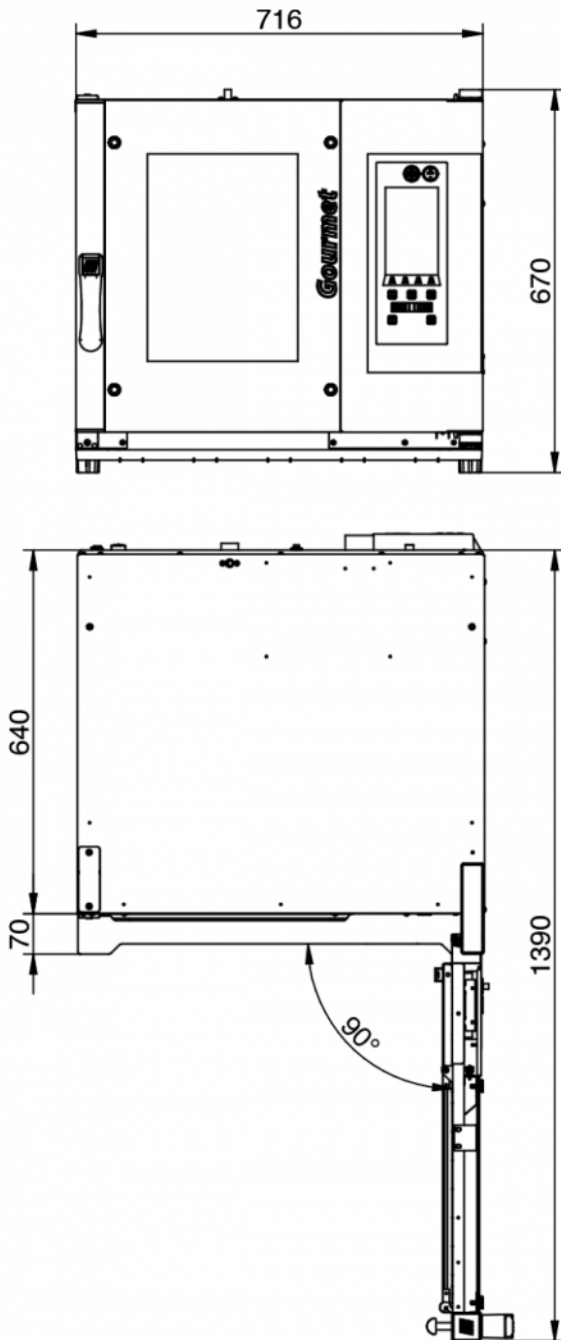
Gourmet 511 Vision
Electrical Supply

Legend

- A - Drain liquid Ø 30mm
- B - Equipotential terminal comb
- C - Electric supply
- D - Water inlet 3/4"
- E - Extracting hood supply
- F - Steam exhaust Ø 50mm
- G - Inlet for washing kit Ø 8mm
- H - Depressurizer Ø 12mm

Gourmet 511 Vision

Electrical Supply

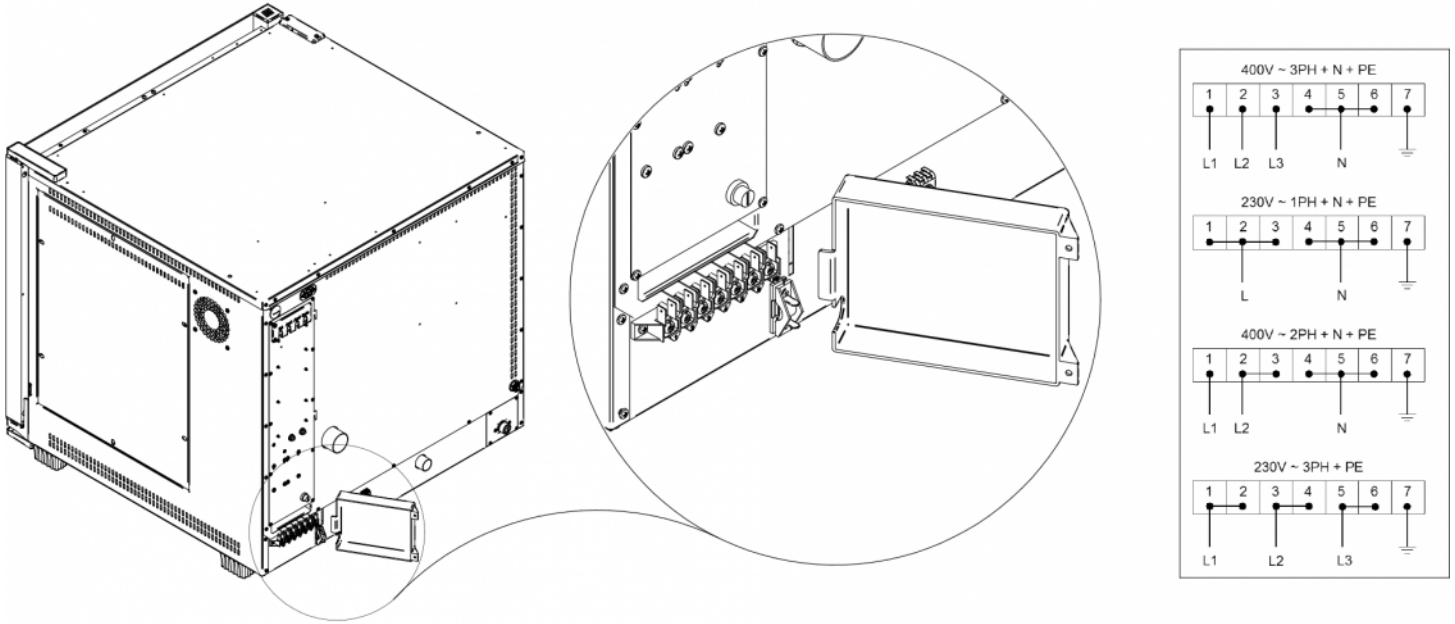
Connections



Packaging

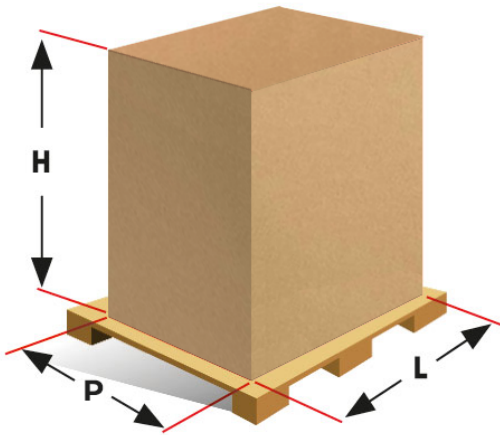

Packing size:	790 L x 870 P x 830 H mm
Net weight:	64 Kg
Gross weight:	73 Kg